

# Hybrid Electric Heat Pump Water Heater Installation Instructions and Use & Care Guide

To obtain technical, warranty or service assistance during or after the installation of this water heater, call toll free  
**1-877-817-6750**

*When calling for assistance, please have the following information ready:*

1. Model number
2. 10 Digit product number
3. Serial number
4. Date of installation
5. Place of Purchase



## Table of Contents

## Page

Water Heater Safety .....	2
Installing Your Water Heater .....	3-9
Consumer Information .....	3
Consumer Responsibilities .....	3
Unpacking Instructions .....	3-4
Location Requirements .....	4
Water System Piping.....	5-6
Temperature & Pressure Relief Valve.....	7-8
Electrical Requirements.....	8-9
Installation Checklist .....	10
Operating Your Water Heater .....	11-14
Before Using .....	11
Water Temperature Regulation .....	11
Adjusting the User Interface Module/Operational Modes .....	12
Operational Conditions .....	13-14
Maintenance of Your Water Heater .....	15-16
Routine Maintenance.....	15
Temperature and Pressure Relief Valve .....	15
Draining and Flushing.....	15-16
Heating Element Replacement.....	16
Diagnostic Codes .....	17
Troubleshooting Chart .....	18
Repair Parts Illustration .....	19

# WATER HEATER SAFETY

## Your safety and the safety of others are very important.

We have provided many important safety messages in this manual and on your appliance. Always read and obey all safety messages.



This is the safety alert symbol.

This symbol alerts you to potential hazards that can kill or hurt you and others.

All safety messages will follow the safety alert symbol and either the word "DANGER" or "WARNING." These words mean:

**⚠ DANGER**

**You can be killed or seriously injured if you don't immediately follow instructions.**

**⚠ WARNING**

**You can be killed or seriously injured if you don't follow instructions.**

All safety messages will tell you what the potential hazard is, tell you how to reduce the chance of injury, and tell you what can happen if the instructions are not followed.

## Important Safety Instructions

**CAUTION:** Hydrogen gas is produced in a hot water system served by this heater that has not been used for a long period of time (2 weeks or more). Hydrogen gas is extremely flammable. To reduce the risk of injury under these conditions, it is recommended that the hot water faucet be opened for several minutes at the kitchen sink before using any electrical appliance connected to the hot water system. When hydrogen is present, there will probably be an unusual sound such as air escaping through the pipe as the water begins to flow. There should be no smoking or open flame near the faucet at the time it is open.

The California Safe Drinking Water and Toxic Enforcement Act requires the Governor of California to publish a list of substances known to the State of California to cause cancer, birth defects, or other reproductive harm, and requires businesses to warn of potential exposure to such substances.

**WARNING:** This product contains a chemical known to the State of California to cause cancer, birth defects, or other reproductive harm.

This appliance can cause low-level exposure to some of the substances included in the Act.

# INSTALLING YOUR WATER HEATER

## Consumer Information

This water heater should be installed in accordance with the local code authority having jurisdiction, the power company or electric utility, and this installation manual. In the absence of local code requirements, follow the regulations set forth in the latest edition of The National Electric Code, NFPA 70. This is available from the following:

National Fire Protection Association  
1 Batterymarch Park  
Quincy, MA 02269

American National Standards Institute  
1430 Broadway  
New York, NY 10018

Check your phone listings for the local authorities having jurisdiction over your installation.

## Consumer Responsibilities

This manual has been prepared to acquaint you with the installation, operation and maintenance of your electric heat pump water heater and to provide important safety information in these areas.

We urge you to read all of the instructions thoroughly before attempting the installation or operation of this water heater. This manual should be kept for future reference.

The manufacturer of this water heater will not be liable for any damages caused by failure to comply with the installation and operating instructions outlined in this manual.

If you lack the necessary skills required to properly install this water heater or you have difficulty following the directions, you should not proceed but have a qualified person perform the installation of this water heater.

Examples of a qualified person include: licensed plumbers, authorized electric company personnel, and authorized service personnel.

Massachusetts code requires this water heater to be installed in accordance with Massachusetts 248-CMR 2.00: State Plumbing Code and 248-CMR 5.00.

A data plate identifying your water heater can be found adjacent to the upper element door. When referring to your water heater always have the information listed on the data plate readily available, to include the model and serial number. Retain your original receipt as proof of purchase.

## Basic Operation Fundamentals

The Heat Pump Water Heater (HPWH) is an integrated heat pump water heater unit, having a compressor and external coil heat exchanger with backup electric elements (Figure 1). When in Efficiency Mode the heat pump draws heat from the ambient air in the room and transfers it to the water in the tank through the coil heat exchanger. The backup element will turn on as a booster if the tank temperature is too low from the set point during high demand period, or if environmental conditions don't provide enough heat to meet demand. While in Electric Mode the

water heater functions like a standard electric water heater, relying on the electric elements to heat the water. A Hybrid Mode is available that relies primarily on the heat pump to heat the water while the electric elements only function during high demand periods. (See "Adjusting the User Interface Module/ Operational Mode" section). The more often the unit operates using the heat pump, rather than the elements, the more efficient the unit will be.

The HPWH uses about half the electricity of a comparably sized conventional electric water heater when operating in the Efficiency/Hybrid Modes, and may provide up to ½ ton cooling capacity and dehumidification. It is designed for indoor, residential applications for installation in a basement, garage or utility room (See "Location Requirements" section).

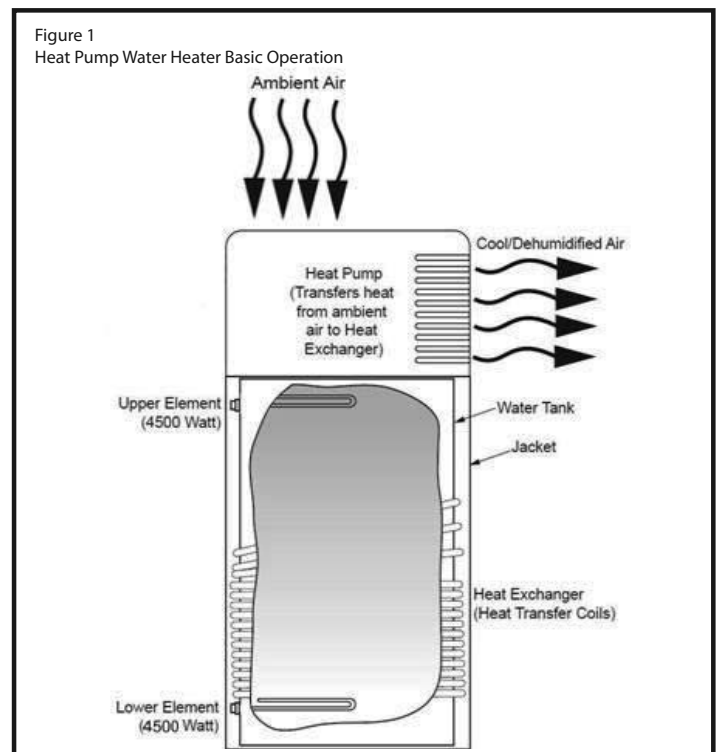

## Unpacking the Water Heater

### ⚠️ WARNING

#### Excessive Weight Hazard

Use two or more people to move and install water heater.

Failure to do so can result in back or other injury.

## Removing Packaging Materials

**IMPORTANT:** Do not remove, cover or deface any permanent instructions, labels, or the data label from either the outside of the water heater or on the inside of water heater panels.

- The water heater may be placed on its designated side (see carton) for local transportation only.
- The water heater must be stored in an upright position.
- Remove exterior packaging and place installation components aside.
- Inspect all parts for damage prior to installation and start-up.
- Completely read all instructions before attempting to assemble and install this product.
- After installation, dispose of/recycle all packaging materials.

## Location Requirements

### Site location

Select a location near the center of the water piping system. The unit must be installed indoors and in a vertical position on a level surface. The flooring beneath the water heater must be able to support the weight of the water heater when filled with water (Table 1).

**IMPORTANT:** The water heater must have unrestricted airflow and requires a minimum installation space of 700 cubic feet. As an example, a room that has an eight foot tall ceiling and is 10 feet long by 8-3/4 feet wide would contain 700 cubic feet.

**NOTE:** To ensure optimal performance and serviceability, a minimum clearance of six (6) inches must be maintained from all sides and six (6) inches from the top for access to the air filter.

The water heater should be located in an area not subject to freezing temperatures. Water heaters located in unconditioned spaces (i.e., garages, basements, etc.) may require the water piping, condensate piping, and drain piping to be insulated to shelter against freezing. The drain and controls must be easily accessible for operation and service. The site location must be free from any corrosive elements in the atmosphere such as sulfur, fluorine, sodium and chlorine. These elements are found in aerosol sprays, detergents, bleaches, cleaning solvents, air fresheners, paint, and varnish removers, refrigerants, and many other commercial and household products. In addition, excessive dust and lint may affect the operation of the unit, see the Air Filter Maintenance section in this manual.

The ambient air temperature must also be considered when installing this unit. In Efficiency Mode the ambient air temperature needs to be above 45°F/7.2 °C and below 120°F/48.8 °C for heat pump operation. If the ambient air temperature falls outside these upper and lower limits the electrical elements will activate to meet the hot water demand and the heat pump does not operate in either Efficiency Mode or Hybrid Mode.

**NOTE:** Local codes and requirements in your area may require the installation of your water heater be accomplished in a way that the bottom element is elevated from the floor at least 18 inches. Ensure that a platform capable of supporting the combined weight of the water heater and water is used.

Capacity	Filled Weight (lbs)
50 Gallon	573
66 Gallon	796
80 Gallon	921

**IMPORTANT:** The water heater should be located in an area where leakage of the tank, connections, condensate lines or condensate will not result in damage to the area adjacent to the water heater or to lower floors of the structure. Due to the normal corrosive action of the water, the tank will eventually leak after an extended period of time. Also, any external plumbing leak, including those from improper installation, may cause early failure of the tank due to corrosion if not repaired. If the homeowner is uncomfortable with making the repair a qualified person should be contacted. A suitable metal drain pan should be installed under the water heater as shown below, to help protect the property from damage which may occur from condensate formation or leaks in the piping connections or tank. The pan must limit the water level to a maximum depth of 2-1/2 inches and be two inches wider than the heater and piped to an adequate drain. Locate the water heater near a suitable indoor drain. Outside drains are subject to freezing temperatures which can obstruct the drain line. The piping should be at least 3/4" ID and sloped for proper drainage. Under no circumstance will the manufacturer or seller of this water heater be held liable for any water damage which is caused by failure to follow these instructions.

Figure 2  
Metal Drain Pan  
Installation

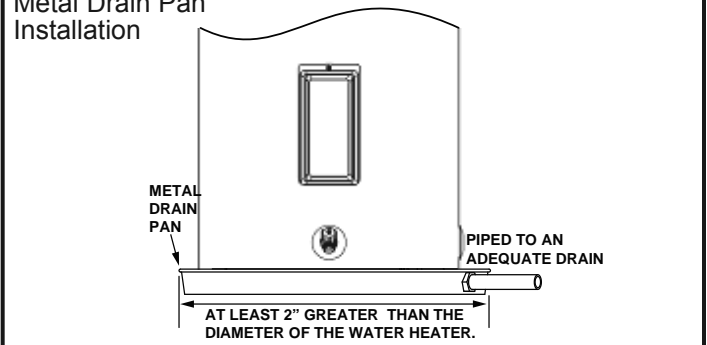

**NOTE:** The water heater shall be located so it is not subject to physical damage by moving vehicles or area flooding.

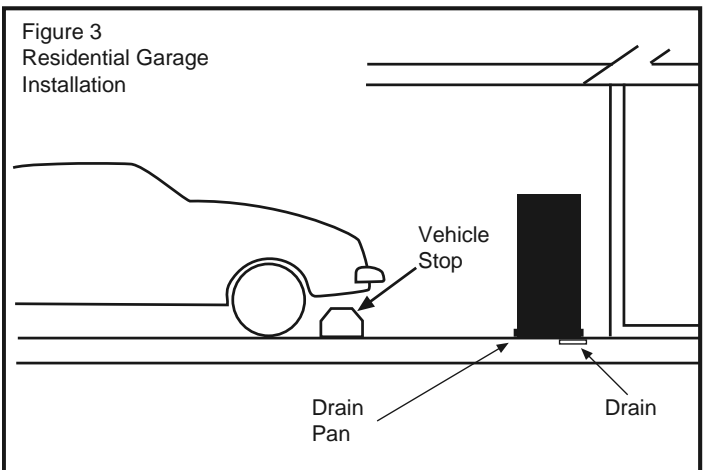

### State of California

**NOTE:** The water heater must be braced, anchored, or strapped to avoid moving during an earthquake. Contact local utilities for code requirements in your area, visit <http://www.dsa.dgs.ca.gov>, or call 1-916-445-8100 and request instructions.

# Water System Piping

Piping, fittings, and valves should be installed according to the installation drawing (Figure 4). If the indoor installation area is subject to freezing temperatures, the water piping must be properly insulated.

Water supply pressure should be 50-60 PSIG and not exceed the maximum 80 PSIG. If the supply line pressure exceeds 80 PSIG, a pressure reducing valve (PRV) with a bypass should be installed in the cold water supply line. This should be placed on the supply to the entire house in order to maintain equal hot and cold water pressures.

**IMPORTANT:**

- **Heat must not be applied to the water fittings on the heater as they may contain nonmetallic parts. If solder connections are used, solder the pipe to the adapter before attaching the adapter to the hot and cold water fittings.**
- Always use a good grade of joint compound and be certain that all fittings are tight.

**IMPORTANT:** DO NOT over apply joint compound.

## Piping Installation

1. Install the water piping and fittings as shown in Figure 4. Connect the cold water supply (3/4" NPT) to the fitting marked "Cold". Connect the hot water supply (3/4" NPT) to the fitting marked "Hot".
2. The installation of unions in both the hot and cold water supply lines are recommended for ease of removing the water heater for service or replacement.

3. Some local codes may require, and the manufacturer of this water heater recommends, installing a mixing valve or an anti-scald device in the domestic hot water line as shown in Figure 4. These valves reduce the point-of-use temperature of the hot water by mixing cold and hot water and are readily available. Contact a licensed plumber or the local plumbing authority for more information.
4. Some local codes may require, and the manufacturer of this water heater recommends, installing a pressure reducing valve (PRV) in the cold water inlet line where it enters the residence as shown in Figure 4.
5. If installing the water heater in a closed water system, install an expansion tank in the cold water line as specified under "Closed System/Thermal Expansion."
6. Install a shut off valve in the cold water inlet line. It should be located close to the water heater and be easily accessible. Know the location of this valve and how to shut off the water to the heater.
7. Install a discharge line from the temperature and pressure relief valve in the opening marked "T & P RELIEF VALVE". (see Figure 4 and the "Temperature and Pressure Relief Valve" section.)
8. After piping has been properly connected to the water heater, open the nearest hot water faucet. Then open the cold water shut off valve and allow the tank to completely fill with water. To purge the lines of any excess air and sediment, keep the hot water faucet open for 3 minutes after a constant flow of water is obtained. Close the faucet and check all connections for leaks.

Figure 4

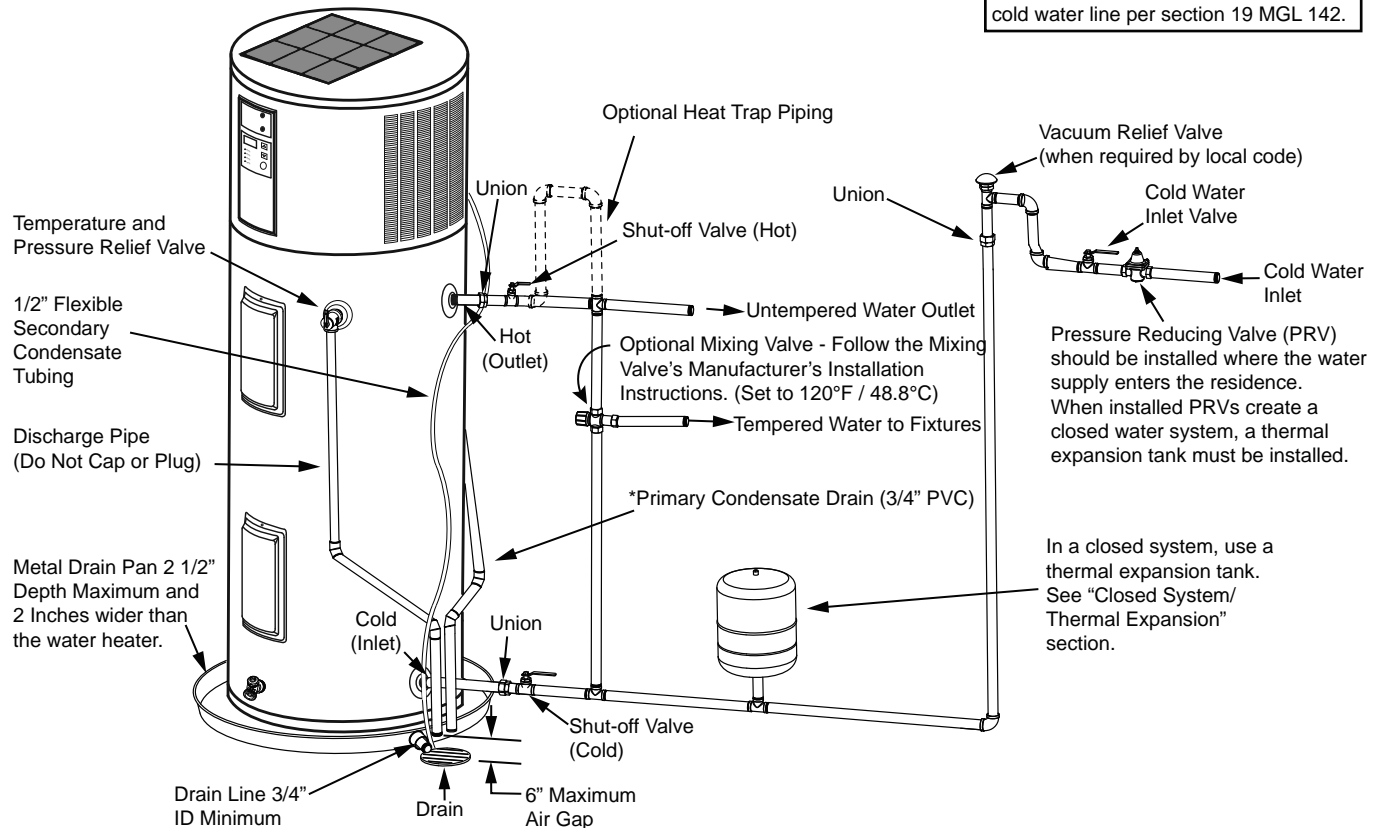

Massachusetts: Install a vacuum relief in cold water line per section 19 MGL 142.

Pressure Reducing Valve (PRV) should be installed where the water supply enters the residence. When installed PRVs create a closed water system, a thermal expansion tank must be installed.

In a closed system, use a thermal expansion tank. See "Closed System/Thermal Expansion" section.

\* If an adequate drain is not available for the condensate drain lines then a condensate pump must be used. DO NOT discharge the condensate drain lines into the metal drain pan.

Please note the following:

- The system should be installed only with piping that is suitable for potable (drinkable) water such as copper, CPVC, PEX or polybutylene. This water heater must not be installed using iron piping or PVC water piping.
- Use only pumps, valves, or fittings that are compatible with potable water.
- Use only full flow ball or gate valves. The use of valves that may cause excessive restriction to water flow is not recommended.
- Use only 95/5 tin-antimony or other equivalent solder. Any lead based solder must not be used.
- Piping that has been treated with chromates, boiler seal, or other chemicals must not be used.
- Chemicals that may contaminate the potable water supply must not be added to the piping system.

## Connecting the Condensate Pump Optional Overflow Shut Off Switch

1. Determine if you have a floor drain, if not a condensate pump will be required.
2. Turn off power to the electrical wiring for the water heater at the circuit breaker/fuse box.
3. Locate the white 18 AWG wire loop close to the drain connections (Figure 5).
4. Cut the loop and strip insulation off of the two ends.

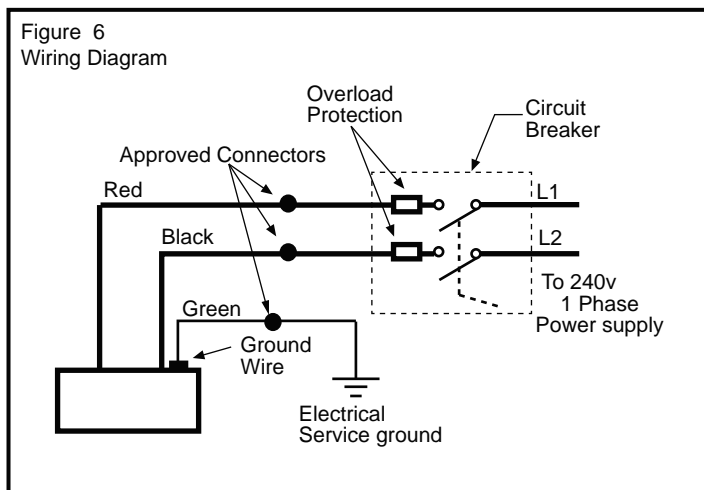
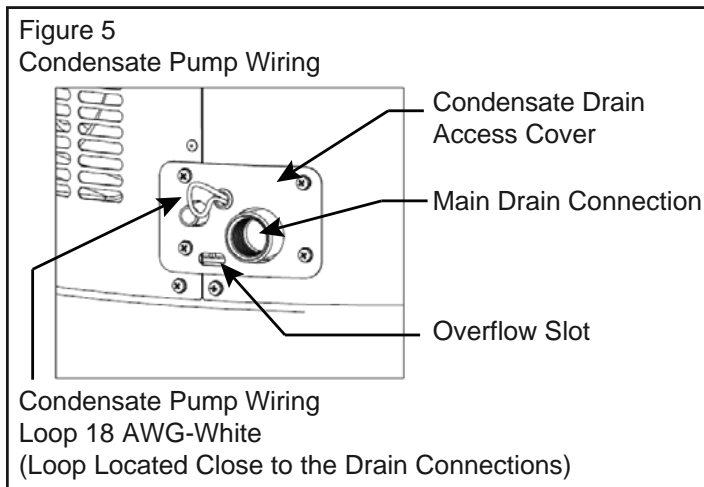

5. Measure the distance from the condensate drain pan cover to the condensate pump, and cut two 18 AWG or larger wires to correct length and strip the insulation at both ends of each wire (Figure 7).
6. Remove the condensate drain pan cover by removing the four screws, pull these two wires through the grommet on the drain pan cover. Connect these two wires to the two wires on the water heater using wire nuts or other connectors. Reinstall the drain pan cover and keep the connection joint inside of the cover.
7. Connect the free ends of the two wires to the shut off switch on the condensate pump in accordance with the condensate pump manufacturers recommendations (Figure 7).
8. Turn on electrical power to the water heater.
9. Select the efficiency mode. After about 8 minutes (the user interface module will display “-”, “--”, “---” repetitively during this period), the heat pump will turn on if the ambient temperature and water temperature meet the heat pump requirement.
10. Test the operation of the shut off switch by unplugging the condensate pump and filling the condensate reservoir with water until the float switch opens the circuit.
11. The heat pump should turn off and the error code “EoF” will appear on the display screen.
12. Plug the condensate pump in and verify that the pump operates and pumps the water out of the condensate reservoir.
13. The error code on the display should clear and the heat pump should operate after 8 minutes.

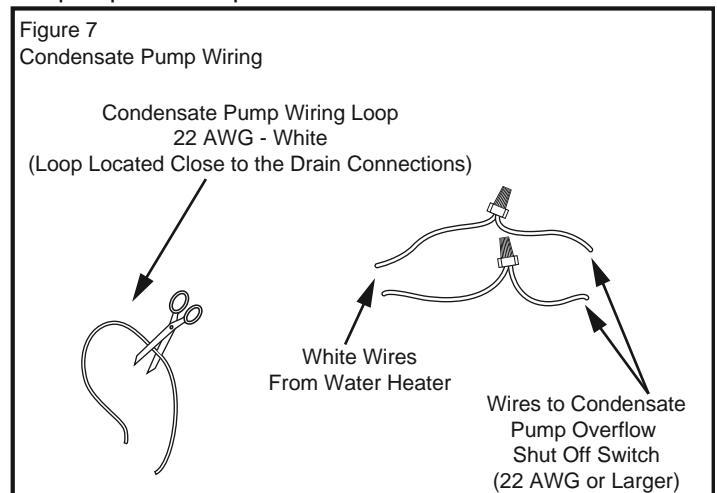

## Condensate Drain Line Installation

The condensate drain lines consist of one 3/4" PVC line as the primary condensate drain line and one 1/2" clear rubber tubing for the condensate over flow. These condensate lines are located on the upper right rear section of your water heater. The lines should terminate a maximum of six inches above an adequate drain. Do not discharge the condensate drain lines into the metal drain pan. If no floor drain is available or the drain is above the level of the condensate line, a condensate pump should be installed. These pumps are available from local distributors.

When installing the drain line, note the following:

**IMPORTANT:** When making condensation connections to the primary connection **DO NOT** over tighten. Overtightening could crack or damage the condensate drain pan.

- Plastic pipe or tubing must be used to connect the condensate drain to a suitable drain or condensate pump.
- Condensate drain lines should be installed in conditioned areas only. Install approved insulation on the condensate drain lines to prevent condensation from forming on the outside of the drain lines. Condensation drain lines installed in areas that are subject to freezing temperatures should be wrapped with a nationally recognized/listed heat tape. Install per manufacturer's instructions.
- Do not connect condensate drain lines with other drain or discharge lines into a single (common) pipe or line. Each line (condensate drain line, temperature and pressure relief valve discharge pipe, etc) should be independently run to an adequate drain.
- Slope the condensate drain lines toward the inside floor drain or condensate pump.
- The condensate drain lines and connections to the drain piping must comply with all local codes.
- Use appropriate fittings, primer and glue to cement the condensate drain lines to the heat pump drain pan.
- If a condensate pump is installed it should shut off the heat pump in the event the condensate pump fails or the float switch in the pump activates. (See section on Condensate Pump Overflow Shut Off Switch in the Electrical Requirements section.)

### Closed System/Thermal Expansion

## ⚠ WARNING



### Explosion Hazard

**If the temperature and pressure relief valve is dripping or leaking, have a qualified person replace it.**

**Examples of a qualified person include: licensed plumbers, authorized electric company personnel, and authorized service personnel.**

**Do not plug valve.**

**Do not remove valve.**

**Failure to follow these instructions can result in death or explosion.**

Most public water systems in North America are required to prevent water flowing from points of use (residences, businesses, etc.) back into the supply system in order to maintain water quality. To accomplish this, back flow preventers such as check valves, are installed in the water line going to each point of use. Typically the back flow preventer will be installed at the water meter or inside a building where the supply line enters the building. This device allows water to flow into the residence but does not allow it to flow back into the water supply. This creates what is known as a "Closed System". As water is heated by the water heater, the water in the system attempts to expand, but has nowhere to go resulting in an increase in pressure. This increase in pressure in the system may cause the temperature-pressure relief valve to open to relieve the pressure. Water will drip from the temperature and pressure relief valve. Premature tank failure will result if this condition is not corrected. To prevent this condition, a properly-sized thermal expansion tank should be installed in the cold water supply to the water heater as shown in Figure 4. Failure to install a properly sized expansion tank in a closed system will void the warranty on the water heater in the event of tank failure. It is important to follow the thermal expansion tank manufacturers' installation instructions and to adjust the expansion tank pressure to match the water supply pressure. Contact a plumbing service agency or your retail supplier regarding the installation of a thermal expansion tank.

## Temperature and Pressure Relief Valve

Figure 8  
Temperature and Pressure Relief Valve Installation

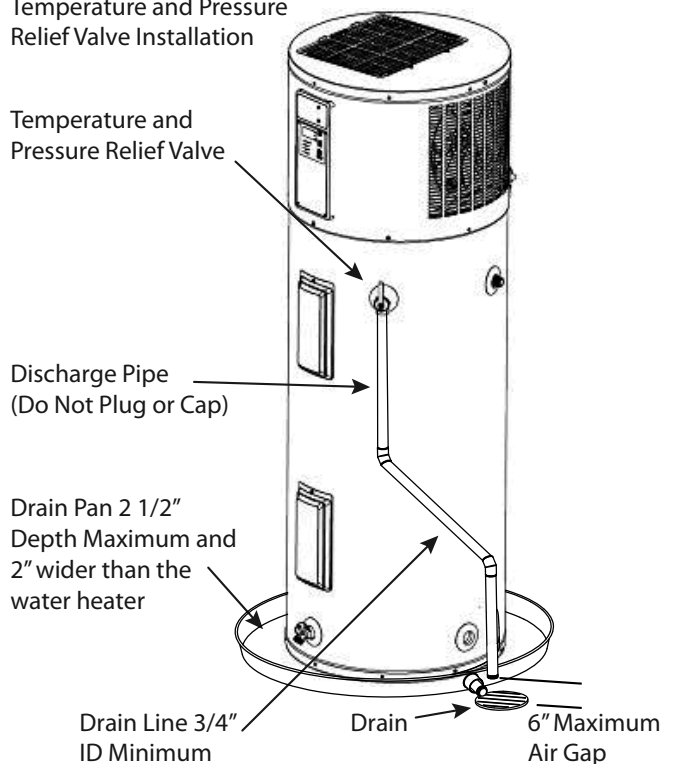

For protection against excessive pressures and temperatures, a temperature and pressure relief valve must be installed in the opening marked "T & P RELIEF VALVE" (Figure 8).

To reduce the risk of excessive pressures and temperatures in this water heater, install temperature and pressure relief protective equipment required by local codes, but no less than a combination temperature and pressure relief valve certified by a nationally recognized testing laboratory that maintains periodic inspection of the production of listed equipment or materials, as meeting the requirements for Relief Valves and Automatic Shutoff Devices for Hot Water Supply Systems, ANSI Z21.22 - latest edition. This valve must be marked with the maximum set pressure not to exceed the marked maximum working pressure of the water heater. Install the valve into an opening provided and marked for this purpose in the water heater, and orient it or provide tubing so that any discharge from the valve exits only within 6 inches above drain, or at any distance below, the structural floor, and does not contact any live electrical part. The discharge opening must not be blocked or reduced in size under any circumstance.

**IMPORTANT:** Only a new temperature and pressure relief valve should be used with your water heater. Do not use an old or existing valve as it may be damaged or not adequate for the working pressure of the new water heater. Do not place any valve between the relief valve and the tank.

**The Temperature & Pressure Relief Valve:**

- Shall not be in contact with any electrical part.
- Shall be connected to an adequate discharge line.
- Shall not be rated higher than the working pressure shown on the data plate of the water heater.

**The Discharge Line:**

- Shall not be smaller than the pipe size of the relief valve or have any reducing coupling installed in the discharge line.
- Shall not be capped, blocked, plugged or contain any valve between the relief valve and the end of the discharge line.
- Shall terminate a maximum of six inches above a floor drain or external to the building. In cold climates, it is recommended that the discharge pipe be terminated at an adequate drain inside the building.
- Shall be of material listed for hot water distribution.
- Shall be installed to allow complete drainage of both the valve and discharge line.

**Temperature/Pressure Relief Valve Insulation**

1. Locate the temperature and pressure relief valve on the water heater, also known as a T&P relief valve (Figure 8).
2. Locate the slit running the length of the T&P relief valve insulation.

3. Spread the slit open and fit the insulation over the T&P relief valve (Figure 9). Apply gentle pressure to the insulation to ensure that it is fully seated on the T&P Relief Valve. Once seated, secure the insulation with duct tape, electrical tape, or equivalent.

**IMPORTANT:** The insulation and tape must not block the discharge opening or hinder access to the manual relief lever (Figure 9). Ensure a discharge pipe is installed into the T&P valve discharge opening per the instructions in this manual.

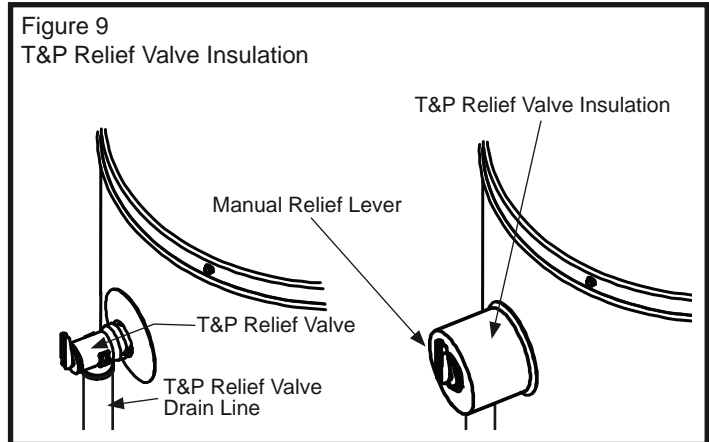

**Electrical Requirements**

<b>⚠ WARNING</b>	
	<b>Electric Shock Hazard</b>
	<p><b>Disconnect power before servicing.</b></p> <p><b>Replace all parts and panels before operating.</b></p>
	<p><b>Failure to do so can result in death or electrical shock.</b></p>

<b>⚠ WARNING</b>	
	<b>Fire Hazard</b>
	<p><b>Use 10 gauge solid copper wire.</b></p> <p><b>Use a UL listed or CSA approved strain relief.</b></p>
	<p><b>Connect ground screw to green ground wire.</b></p> <p><b>Failure to do so can result in death, fire, or electrical shock.</b></p>



If you lack the necessary skills required to properly install the electrical wiring to this water heater, do not proceed but have a qualified electrician perform the installation.

When making the electrical connections, always make sure:

- The electrical service provides 240 VAC to the water heater for proper operation. DO NOT use 208 VAC.
- Wire sizes and connections comply with all applicable codes or in the absence of local or state codes follow NFPA-70, the National Electrical Code-current edition.
- Wiring enclosed in approved conduit (if required by local codes).
- The water heater and electrical supply are properly grounded.
- The electrical supply has the proper overload fuse or breaker protection.

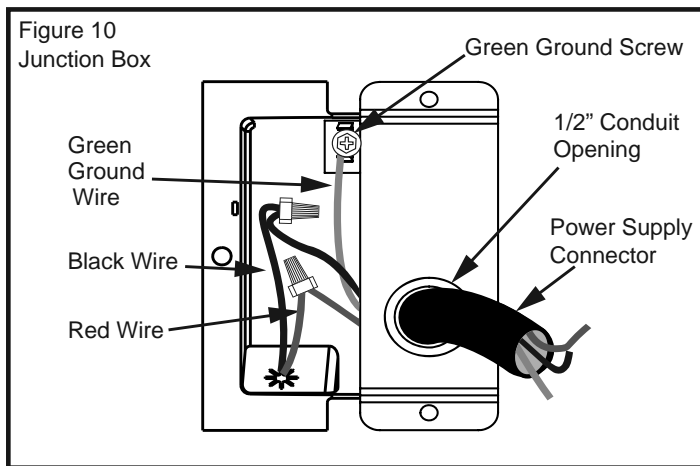

Always reference the wiring diagram located on the water heater for the correct electrical connections and connect the electrical supply to the water heater in accordance with local utility requirements and codes.

When installing the electrical wiring to the water heater:

1. Although this water heater is equipped with “Dry Fire” protection, be sure tank is completely filled with water, and all air is purged from the tank before making any electrical connections. See “Draining and Flushing Section”.
2. Turn off power to the electrical wiring for the water heater at the circuit breaker/fuse box.
3. If metal conduit is used for the grounding conductor:
  - A. The grounding electrode conductor shall be of copper, aluminum, or copperclad aluminum. The material shall be of one continuous length without a splice or joint.
  - B. Rigid metal conduit, intermediate metal conduit, or electrical, metallic tubing may be used for the grounding means if conduit or tubing is terminated in fittings approved for grounding.
  - C. Flexible metal conduit or flexible metallic tubing shall be permitted for grounding if all the following conditions are met:
    - The length in any ground return path does not exceed 6 feet.
    - The circuit conductors contained therein are protected by overcurrent devices rated at 30 amperes.

- The conduit or tubing is terminated in fittings approved for grounding.

For complete grounding details and all allowable exceptions, refer to the current edition of the National Electrical Code NFPA 70.

4. A standard 1/2" conduit opening has been made in the water heater junction box for the conduit connections.
5. Use wire nuts and connect the power supply wiring to the wires inside the water heater's junction box (Figure 10).
6. The water heater must be electrically "grounded" by the installer. A green ground screw has been provided on the water heater's junction box. Connect ground wire to this location.
7. Replace the wiring junction box cover using the screw provided.
8. Turn on electrical power to the water heater.
9. Press the Efficiency button to set the operating mode.  
**NOTE:** The water heater will conduct a system diagnostic (approximately 8 minutes) prior to returning to operation.
10. Once the diagnostic sequence has finished, the fan should turn on.  
**NOTE:** The heat pump's fan will not turn on if the incoming water temperature is less than 59°F / 15°C and/or the ambient air temperature is above 120°F / 15°C or below 45°F / 7.2°C. Should the internal diagnostics detect a problem with the heat pump, an error code will be displayed.
11. Set the desired operational mode. For typical installations, the Hybrid Mode offers the best combination of efficiency and hot water delivery. For detailed descriptions of all operational modes see “Adjusting the User Interface Module/Operational Modes” section.

## Insulation Blankets

The use of an insulation blanket on this water heater is not needed or recommended. The purpose of an insulation blanket is to reduce the standby heat loss encountered with storage tank heaters. Your water heater meets or exceeds the National Appliance Energy Conservation Act standards with respect to insulation and standby loss requirements, making an insulation blanket unnecessary. If an insulation blanket is installed, make sure it does not block airflow into or out of the compressor assembly.

# INSTALLATION CHECKLIST

## Water Heater Location

- Centrally located with the water piping system.
- The flooring beneath the water heater must be able to support the weight of the water heater when filled with water (Table 1).
- Located indoors (such as a basement or garage) and in a vertical position. Sheltered from freezing temperatures.
- Provisions made to shelter the area from water damage. Metal drain pan installed and piped to an adequate drain.
- Sufficient room to service the water heater.
- The water heater must have unrestricted airflow and requires a minimum installation space of 700 cubic feet. As an example, a room that has an eight foot tall ceiling and is 10 feet long by 8-3/4 feet wide would contain 700 cubic feet.

**NOTE:** This Heat Pump Water Heater may be located within a required minimum of 6" clearance from a wall on the outlet side, however for future service considerations a minimum clearance of 3 feet from any obstruction on the back, left and right side is recommended.

- The unit cannot be placed into any type of closet or small enclosure, unless adequate provision is made for air exchange (vented or louvered doors, etc.).
- The site location must be free from any corrosive elements in the atmosphere such as sodium, sulfur, fluorine, and chlorine. These elements are found in aerosol sprays, detergents, bleaches, cleaning solvents, air fresheners, paint, and varnish removers, refrigerants, and many other commercial and household products. In addition excessive dust and lint may affect the operation of the unit and require more frequent cleaning (See "Preventive Maintenance" section).
- Ambient air temperature should be above 45°F / 7.2°C and below 120°F / 48.8°C. If the ambient air temperature falls outside these upper and lower limits the electrical elements will activate to meet the hot water demand.

## Water System Piping

- Temperature and pressure relief valve properly installed with a discharge pipe run to an adequate drain and sheltered from freezing (Figure 8).
- All piping properly installed and free of leaks.
- Heater completely filled with water (See "Water Piping System" section).
- Closed system pressure buildup precautions installed (See "Closed System/Thermal Expansion" section).
- Mixing valve (when applicable) installed per manufacturer's instructions (See "Water Temperature Regulation" section).

## Condensate Drain Line Installation

- Must be located with access to an adequate drain or condensate pump.
- Condensate drain lines installed and piped to an adequate drain or condensate pump (Figure 4).

## Electrical Connections

- This water heater requires a 240 VAC single phase 30 amp power supply. DO NOT use a 208 VAC service.
- Wiring size and connections comply with all applicable codes or in the absence of local or state codes follow NFPA-70, the National Electrical Code-current edition.
- Water heater and electrical supply are properly grounded.
- Wiring enclosed in approved conduit (if required by local codes).
- Proper overload fuse or circuit breaker protection installed.

## Post Installation Review

- Understand how to use the User Interface Module to set the various modes and functions (See "Adjusting the User Interface Module/Operating Modes" section).
- Hybrid Mode is the recommended Operating Mode. Understand the various Operating Modes and which mode may be best based on season, ambient temperature, and usage (See "Operating Mode Description" section).  
Understand the importance of routine inspection/maintenance of the condensate drain pan and lines (See "Inspection/Cleaning of the Condensate Drain Pan & Condensate Drain Lines" section). This is to help prevent any possible drain line blockage resulting in the condensate drain pan overflowing.  
**IMPORTANT:** If water is coming from the overflow-slot of the condensate drain pan cover (Figure 11) this indicates that both condensation drain lines may be blocked. Immediate action is required.

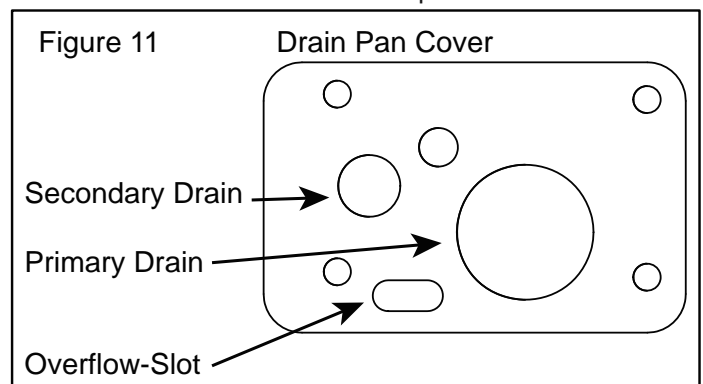

- To maintain optimal operation, check, remove and clean the air filter as needed (See "Air Filter Cleaning/Replacement" section).
- The Installation Instructions and Use & Care Guide should be kept with the water heater for reference.

# OPERATING YOUR WATER HEATER

## Before Using

1. Make sure the water heater has been properly installed. See “Installing Your Water Heater” section.
2. Make sure the air filter is correctly seated, as it may shift during shipping or installation.  
**NOTICE:** Make certain that there are no obstructions on top of the unit that may block inlet or exhaust air flow. See “Repair Parts Illustration” section.
3. Completely fill the tank with water (See “Water Piping” section).
4. After the water heater tank is completely filled with water, connect electrical power to the water heater.
5. Read the “Water Temperature Regulation” section of this manual. If you do not fully understand these instruction, contact a qualified person.
6. When powered on the unit will start to run a system diagnostic. This typically takes eight minutes, (the user interface module will display “-”, “--”, “---” repetitively during this period). Once complete, proceed to the next step.  
**NOTE:** If the system diagnostic yields any codes, reference the Diagnostic Code section in this manual.
7. Adjust the thermostat to the desired temperature setting as described under “Adjusting the User Interface Module/Operational Modes” section.

**IMPORTANT:** Do not attempt to operate this water heater if the unit has been submerged, subjected to flooding, or surrounding insulation has been exposed to water in any way.

Do not attempt to repair a unit subjected to flood conditions. Water heaters subjected to flood conditions or any time the unit has been submerged in water require replacement of the entire water heater.

### Safety Shut-off (ECO)

This water heater is designed to automatically shut-off in the event that the water temperature exceeds 190°F / 87.8°C. A temperature limit switch or ECO (Energy Cut Off) is used to shut off the power to the system if the water temperature exceeds 190°F / 87.8°C (See “Water Temperature Regulation” section). To reset the ECO disconnect power at the circuit breaker/fuse box then remove the upper access panel. Reset the ECO by firmly pushing in the red reset button located on the ECO block. If the ECO continues to shut-off the water heater, contact a qualified person for service.

## Water Temperature Regulation

**⚠ WARNING**

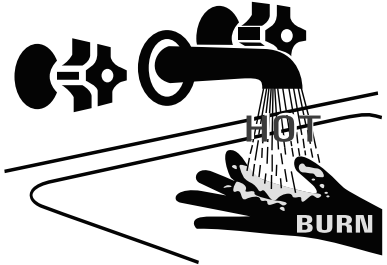

**Water temperature over 125°F can cause severe burns instantly or death from scalds.**

**Children, disabled and elderly are at highest risk of being scalded.**

**Feel water before bathing or showering.**

**Temperature limiting valves are available.**

The water heater is adjusted to a temperature setting of no higher than 120°F / 48.8°C when it is shipped from the factory. Water temperature can be regulated by adjusting the User Interface Module to the preferred setting as shown in “Adjusting the User Interface Module/Operational Mode” The preferred starting point is 120°F / 48.8°C. There is a hot water scald potential if the temperature set point is set too high.

**IMPORTANT:** Adjusting the set point above 120°F / 48.8°C on the User Interface Module will increase the risk of scald injury in the times shown below.

Water Temperature °F/°C	Time for 1st Degree Burn (Less Severe Burns)	Time for Permanent Burns 2nd & 3rd Degree (Most Severe Burns)
110°/43.3°	(normal shower temp.)	
116°/46.6°	(pain threshold)	
116°/46.6°	35 minutes	45 minutes
122°/50°	1 minute	5 minutes
131°/55°	5 seconds	25 seconds
140°/60°	2 seconds	5 seconds
149°/65°	1 second	2 seconds
154°/67.7°	instantaneous	1 seconds

(U.S. Government Memorandum, C.P.S.C., Peter L. Armstrong, Sept. 15, 1978)



**NOTE:** During low demand periods when hot water is not being used, a lower temperature set point will reduce energy losses and may satisfy your normal hot water needs. If hot water use is expected to be more than normal, a higher temperature set point may be required to meet the increased demand.

When leaving your home for extended periods (vacations, etc.) set the water heater to Vacation Mode. See “Adjusting the User Interface Module/Operational Modes” section. This will maintain the water at low temperatures with minimum energy losses and prevent the tank from freezing during cold weather.

**NOTE:** When returning from an extended stay remember to set the water heater back to the desired Operational Mode. 11

# Adjusting the User Interface Module/Operational Modes

## Water Temperature Adjustment

The water temperature can be adjusted from 95°F / 35°C to 140°F / 60°C. Use the Up and Down Buttons   on the front panel to set the desired temperature. The setting temperature will blink on the display, press Mode/Enter button to confirm.

The water temperature can be adjusted quickly by pressing the “Temperature Up” button and holding for three seconds.

**IMPORTANT:** Before attempting to adjust the thermostat, read the “Water Temperature Regulation” section. If the instructions are not clear, contact a qualified person.

**IMPORTANT:** For increased water demand, switching (temporarily) to Hybrid Mode or Electric Mode will decrease the recovery/re-heat time. Be sure to switch back to the desired operational mode when finished.

## Operating Mode Descriptions

The operating modes can be changed sequentially by pressing the Mode/Enter button (Figure 12). The Operation Mode Indication Light will turn on when the relevant mode is selected.

This unit is equipped with technology that senses the amount of water drawn from the unit. While in Efficiency or Hybrid mode, during normal usage, the unit will operate the heat pump for maximum efficiency. In times that the water usage is above normal, this unit has the ability to use one element (upper or lower) and the heat pump simultaneously to help improve recovery. This transition is seamless and will go unnoticed.

- ◇ Efficiency Mode - Provides the highest efficiency and lowest cost operation by using only the heat pump for heating. Recovery time and efficiency will vary with ambient temperature and relative humidity. Efficiency will be greatest, and recovery quickest, when both are high. At lower temperatures and relative humidity levels, efficiency will be lower and recovery will take longer. Heat pump operation is allowed from 45°F / 7.2°C ambient temperature. At ambient temperatures lower than 45°F / 7.2°C and greater than 120°F / 48.8°C, the heat pump will not operate. Similarly, if the water temperature in the tank is less than 59°F / 15°C, the heat pump will not operate. The unit will operate in electric mode until ambient and water temperatures return to the safe operating range of the heat pump.

- ◇ Hybrid Mode - This is the default, recommended setting, combining high energy efficiency with reduced recovery time. This mode uses the heat pump as the primary heating source. The heating element will heat water if demand exceeds a predetermined level so that the set point temperature can be recovered more quickly.
- ◇ Electric Mode - The water heater functions as a conventional electric unit, relying on only the elements for heat. This mode may be useful in winter to eliminate the output of cold air from the unit.
- ◇ Vacation Mode - The controller adjusts the water temperature to approximately 60°F. This mode is recommended when the water heater is not in use for a long period of time, to minimize energy consumption and prevent the water heater from freezing during cold conditions.

**NOTE:** When Vacation Mode is selected, the vacation timer will be displayed. Press the Up and Down button to modify the timer to desired number of vacation days (setting range: 1 to 99 days). The vacation timer will blink on the display; press the Mode/Enter button to confirm the vacation timer. To deactivate Vacation Mode, press the Mode/Enter button to switch to the desired mode.

**IMPORTANT:** Do not shut off power to the unit for extended periods of time. If power must be turned off for an extended period of time, drain the tank completely.

**CAUTION:** Hydrogen gas is produced in a hot water system served by a heater that has not been used for a long period of time (2 weeks or more). Hydrogen gas is extremely flammable. To reduce the risk of injury under these conditions, it is recommended that the hot water faucet be opened for several minutes at the kitchen sink before using any electrical appliance connected to the hot water system. When hydrogen is present, there will probably be an unusual sound such as air escaping through the pipe as the water begins to flow. There should be no smoking or open flame near the faucet at the time it is open.

## Other Controls

**°F/°C** °F/°C Switch - Press “Temperature Down” button and hold for 3 seconds to switch temperature unit between Fahrenheit and Celsius

**Power Saver Enable/Disable** - Press “Mode/Enter” button and hold for 3 seconds. The power saver feature will be activated and the display will show “P.S.”, and the setting temperature alternatively. This feature allows the unit to be managed by grid or other utility based load management programs.

To deactivate the power saver, press “Mode/Enter” button and hold for 3 seconds.

**Heat pump defrosting indication** - There will be frost accumulating on the evaporator when the heat pump is operated under low ambient temperatures. The controller will order the unit to enter into defrosting cycle to optimize the heat pump operation performance. During the defrosting period, the user interface module will display “ICE” as an indication.

**Out of heat pump operation range** - The user interface module will display “HPO” as an indication that the ambient and/or water temperature condition is out of the heat pump operation range.

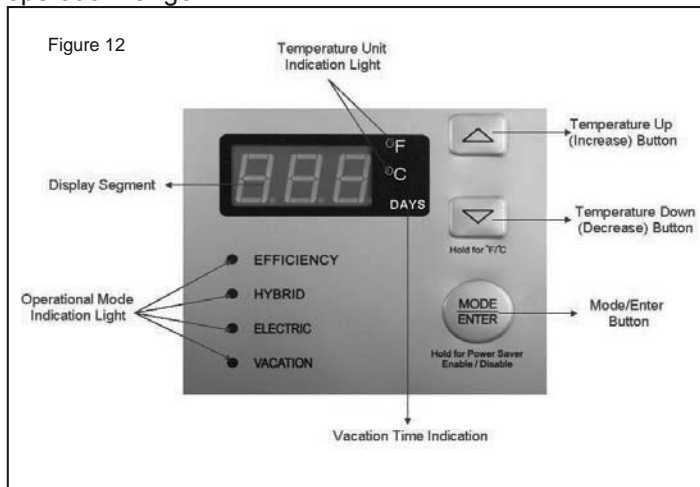

**NOTE:** The display will go into “Sleep Mode” for energy saving if there is no operation on any button for 15 minutes. All the display and light will be turned off except for the “Operational Mode Indication Light”, which will be on all the time when the unit is powered on. The unit will be awakened by pressing any button.

## Operational Conditions

### Water Odor

In each water heater there is installed at least one anode rod (see parts sections) for corrosion protection of the tank. Certain water conditions will cause a reaction with this rod and the water. The most common complaint associated with the anode rod is one of a "rotten egg smell" in the hot water. This odor is derived from hydrogen sulfide gas dissolved in the water. The smell is the result of four factors which must all be present for the odor to develop:

- A. A concentration of sulfate in the supply water.
- B. Little or no dissolved oxygen in the water.
- C. A sulfate reducing bacteria which has accumulated within the water heater (this harmless bacteria is nontoxic to humans).
- D. An excess of active hydrogen in the tank. This is caused by the corrosion protective action of the anode.

Smelly water may be eliminated or reduced in some water heater models by replacing the anode(s) with one of less active material, and then chlorinating the water heater tank and all hot water lines. Contact the local water heater supplier or service agency for further information concerning an Anode Replacement Kit and the chlorination treatment. If the smelly water persists after the anode replacement and chlorination treatment, we recommend that chlorination or aeration of the water supply be considered to eliminate the water problem.

### Water Heater Sounds

During the normal operation of the water heater, sounds or noises may be heard. These noises are common and may result from the following:

1. Normal expansion and contraction of metal parts during periods of heat-up and cool-down.
2. Sediment buildup on or around the elements could create varying amounts of noise and may cause premature tank failure. Drain and flush the tank as directed under the “Draining and Flushing” section.
3. The heat pump compressor or fan running.

### Stacking

Stacking occurs when a series of short hot water draws (3 gallons or less) are made. This causes increased cycling of the heat pump and/or heater elements and can result in increased water temperatures at the hot water outlet. An anti-scald device is recommended in the hot water supply line to reduce the risk of scald injury.

Do not remove the anode leaving the tank unprotected. By doing so, all warranty on the water heater tank is voided.

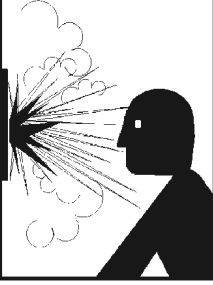
	<h2>⚠ WARNING</h2> <h3>Explosion Hazard</h3>
	<ul style="list-style-type: none"> <li>• Flammable hydrogen gases may be present.</li> <li>• Keep all ignition sources away from faucet when turning on hot water.</li> </ul>

### "AIR" IN HOT WATER FAUCETS

**HYDROGEN GAS:** Hydrogen gas can be produced in a hot water system that has not been used for a long period of time (generally two weeks or more). Hydrogen gas is extremely flammable and explosive. To prevent the possibility of injury under these conditions, we recommend the hot water faucet, located farthest away, be opened for several minutes before any electrical appliances which are connected to the hot water system are used (such as a dishwasher or washing machine). If hydrogen gas is present, there will probably be an unusual sound similar to air escaping through the pipe as the hot water faucet is opened. There must be no smoking or open flame near the faucet at the time it is open.

### HIGH WATER TEMPERATURE SHUT OFF SYSTEM

A non-adjustable high temperature limit control operates before steam temperatures are reached. The high limit is in the same area as the upper thermostat and must be reset manually when it operates. **BECAUSE THE HIGH LIMIT OPERATES ONLY WHEN ABNORMALLY HIGH WATER TEMPERATURES ARE PRESENT, IT IS IMPORTANT THAT A QUALIFIED SERVICE AGENT BE CONTACTED TO DETERMINE THE REASON FOR OPERATION BEFORE RESETTING.**

	<h2>⚠ WARNING</h2>
	<ul style="list-style-type: none"> <li>• Before removing any access panels or servicing the water heater, make sure the electrical supply to the water heater is turned "OFF."</li> <li>• Failure to do this could result in death, serious bodily injury, or property damage.</li> </ul>

- Turn off the heater electrical supply. Do not attempt to reset thermostat with power on.
- Remove the screw securing the outer door and remove door.
- Fold up the insulation to expose the reset button.
- Reset the high limit by pushing the red button marked "reset".
- Replace the insulation so that it completely covers the thermostat and element.
- Replace the outer door.
- Turn "ON" electric power to the water heater.

### ANODE ROD INSPECTION

<h1>CAUTION</h1> <h2>Property Damage Hazard</h2>
<ul style="list-style-type: none"> <li>• Avoid water heater damage</li> <li>• Inspection and replacement of anode rod recommended</li> </ul>

Each water heater contains at least one anode rod, which will slowly deplete (due to electrolysis) prolonging the life of the water heater by protecting the glass lined tank from corrosion. Adverse water quality, hotter water temperatures, high hot water usage, hydronic heating devices and water softening methods can increase the rate of anode rod depletion. Once the anode rod is depleted, the tank will start to corrode, eventually developing a leak.

Certain water conditions will cause a reaction between the anode rod and the water. The most common complaint associated with the anode rod is a "rotten egg smell" produced from the presence of hydrogen sulfide gas dissolved in the water. **IMPORTANT:** Do not remove the anode rod permanently as it will void any warranties. A special anode rod may be available if water odor or discoloration occurs. **NOTE:** This anode rod may reduce but not eliminate water odor problems. The water supply system may require special filtration equipment from a water conditioning company to successfully eliminate all water odor problems.

Artificially softened water is exceedingly corrosive because the process substitutes sodium ions for magnesium and calcium ions. The use of a water softener may decrease the life of the water heater tank.

The anode rod should be inspected after a maximum of three years and annually thereafter until the condition of the anode rod dictates its replacement. **NOTE:** Artificially softened water requires the anode rod to be inspected annually.

The following are typical (but not all) signs of a depleted anode rod (Figure 13):

- The majority of the diameter is less than 3/8".
- Significant sections of the support wire (approx, 1/3 or more of the anode rod's length) are visible.

If the anode rod shows signs of either or both it should be replaced.

**NOTE:** Whether re-installing or replacing the anode rod, check for any leaks and immediately correct if found.

In replacing the anode:

1. Turn off power to the water heater.
2. Shut off the water supply and open a nearby hot water faucet to depressurize the water tank.
3. Drain approximately 5 gallons of water from the tank. (Refer to "Draining and Flushing" for proper procedures). Close drain valve.
4. Remove old anode rod.
5. Use Teflon® tape or approved pipe sealant on threads and install new anode rod.
6. Turn on water supply and open a nearby hot water faucet to purge air from water system. Check for any leaks and immediately correct any if found.
7. Restart the water heater as directed in this manual. See the repair part illustration for anode rod location.

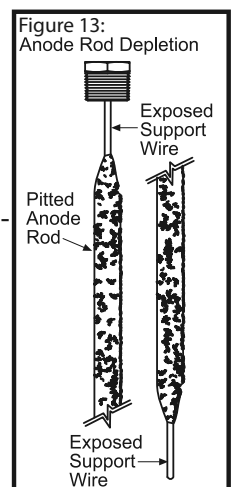

# MAINTENANCE OF YOUR WATER HEATER

## Routine Maintenance

Routine visual inspections should be made of the following:

- Remove and inspect the air filter, clean if needed, and reinstall - quarterly.
- Condensate drain pan and condensate lines - annually.
- The lower metal drain pan for standing water which may indicate a clogged condensate drain pan, condensate lines, or plumbing leak - annually.
- Leaking or damaged water piping - annually.
- Presence of corrosive materials in the installation area - annually.
- Presence of combustible materials near the water heater - annually.
- After servicing this water heater, check to make sure it is working properly. (See "Operating Your Water Heater" section of this manual.)

**IMPORTANT:** If you lack the necessary skills required to properly perform this visual inspection, you should not proceed, but get help from a qualified person.

## Air Filter Maintenance

The heater will monitor the heat pump operation status and indicate whether the filter should be cleaned. If the User Interface Module displays "SF" code, this indicates the filter should be cleaned or replaced with the following process (See exploded view of unit on last page for air filter location).

**IMPORTANT:** Before attempting to clean or replace the air filter, turn-off power to the water heater at the circuit breaker/fuse box.

1. Take the two tabs on the air filter and remove (slide) it from the top cover of the unit.
2. If you are replacing the filter skip to step 4. To clean the filter use a vacuum with a hose attachment to remove any dust or debris.
3. Place the new or cleaned filter into the water heater.
4. Restore power to the water heater and turn the water heater on. **NOTE:** the water heater will conduct a system diagnostic prior to operation.

## Condensate Drain Maintenance

**IMPORTANT:** Before attempting to clean or replace the condensate drain pan or lines, shut-off power to the water heater at the circuit breaker/fuse box.

1. Remove the top jacket by loosening the screws securing it to the unit.
2. Check the condensate drain pan and drain lines for any dirt or debris that might interfere with proper drainage. Wipe out any dirt or debris with a damp cloth.
3. Once the condensate drain pan and lines have been inspected/cleaned, secure the top jacket to the water heater.
4. Restore power to the water heater and turn the water heater on.

**NOTE:** The water heater will conduct a system diagnostic prior to operation.

## Temperature and Pressure Relief Valve

### ⚠ WARNING



### Explosion Hazard

**If the temperature and pressure relief valve is dripping or leaking, have a qualified person replace it.**

**Examples of a qualified person include: licensed plumbers, authorized electric company personnel, and authorized service personnel.**

**Do not plug valve.**

**Do not remove valve.**

**Failure to follow these instructions can result in death or explosion.**

Manually operate the temperature and pressure relief valve once a year to make sure it is working properly (Figure 14).

To prevent water damage, the valve must be properly connected to a discharge line which terminates at an adequate drain.

Standing clear of the outlet (discharged water may be hot), slowly lift and release the lever handle on the

temperature and pressure relief valve to allow the valve to operate freely and return to its closed position. If the valve fails to completely reset and continues to release water, immediately disconnect the electrical power, close the cold water inlet valve and call a qualified person.

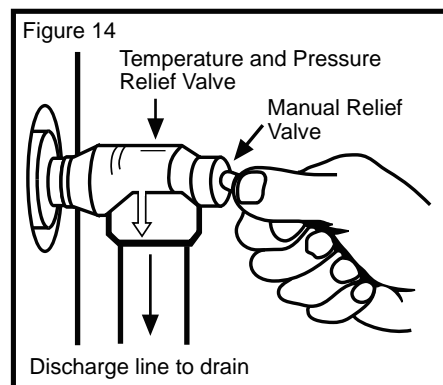

# Draining and Flushing

It is recommended that the tank be drained and flushed every 6 months to remove sediment which may build up during operation. The water heater should be drained if being shut down during freezing temperatures. To drain the tank, perform the following steps:

1. Turn off the power to the water heater at the circuit breaker/fuse box.
2. Open a nearby hot water faucet until the water is no longer hot.
3. Close the cold water inlet valve.
4. Connect a hose to the drain valve and terminate it to an adequate drain or external to the building.
5. Open the water heater drain valve and allow all of the water to drain from the tank. Flush the tank with water as needed to remove sediment.
6. Close the drain valve, refill the tank (open the cold water inlet valve), and restart the heater as directed in this manual.

**IMPORTANT:** Do not turn on power to the water heater unless it is completely filled with water. To ensure that the tank is full, open a hot water faucet and allow the water to run until the air is purged and the water flows uninterrupted from the faucet.

**NOTE:** The water heater will conduct a system diagnostic prior to operation.

If the water heater is going to be shut down for an extended period, the drain valve should be left open.

# Heating Element Replacement

<b>⚠ WARNING</b>	
	<b>Electric Shock Hazard</b>
	<b>Disconnect power before servicing.</b>
	<b>Replace all parts and panels before operating.</b>
<b>Failure to do so can result in death or electrical shock.</b>	

Replacement heating elements must be of the same style and voltage/wattage rating as the ones originally in the water heater. This information can be found on the flange or terminal block of the element or on the water heater data plate.

**IMPORTANT:** Before replacing any element, confirm that you have the correct replacement element (wattage). This water heater has a 4500 watt upper element and a 4500 watt lower element. DO NOT replace the element(s) with a wattage different than the ones specified for the upper and/or lower element.

**IMPORTANT:** Using an element greater than 4500 watts will damage the water heater and void the warranty.

1. Turn off the power to the water heater.
2. Drain the water heater as directed in the "Draining and Flushing" section.

3. Remove the access cover(s), then take off the white fiber dam.
4. Remove the protective plastic cover(s) over the elements from their attachment point.
5. Disconnect the electrical wires from the heating element(s) by loosening the screws (Figure 15). Remove the screw-in element(s) by turning the element(s) counterclockwise with a 1-1/2 inch socket wrench. Remove the existing gasket(s)

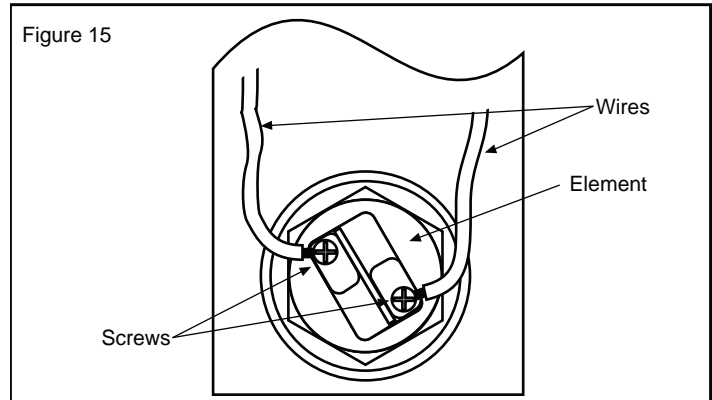

6. Clean the area where the gasket(s) fits to the tank and internal threads. If you are replacing the bottom element, remove any accumulated sediment on the bottom of the tank.
7. Make sure the replacement element(s) has the correct voltage and wattage rating by matching it to the rating plate on the water heater. Position the new gasket(s) on the element and insert it into the water heater tank (Figure 16).

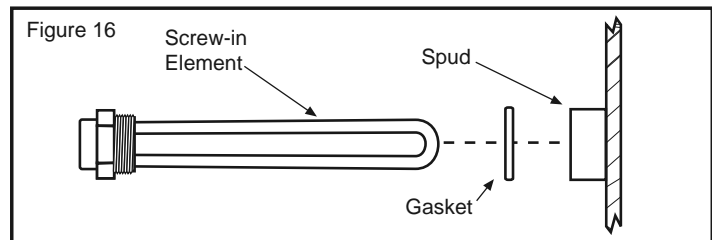

**NOTE:** Apply a light coat of hand dishwashing soap and water to the gasket. Tighten the element by turning it clockwise until secure.

8. Close the drain valve and open the nearest hot water faucet. Then open the cold water shut off valve and allow the tank to fill completely with water. To purge the lines of any excess air and sediment, keep the hot water faucet open for 3 minutes after a constant flow of water is obtained.
9. Check for leaks around the element(s).
10. Reconnect the electrical wires to the element and securely tighten the screws (Figure 15).
11. Replace the protective plastic cover(s) removed earlier. Make sure the cover(s) are securely engaged on the attachment point(s).
12. Replace the white fiber dam and access cover(s).
13. Although this water heater is equipped with "Dry Fire" protection circuitry, be sure tank is completely filled with water before applying electrical power to the water heater.
14. Reconnect electrical power to the water heater at the circuit breaker/fuse box.
15. Set the desired water temperature and operating mode. **NOTE:** The water heater will conduct a system diagnostic (approximately 8 minutes) prior to operation.



# DIAGNOSTIC CODES

DISPLAY SHOWS	INDICATES	CORRECTIVE ACTION
<b>EUC</b>	Upper element is not functioning	<ol style="list-style-type: none"> <li>1. Turn off power at the circuit breaker/fuse box and check for a loose connection at the element. For access directions see "Heating Element Replacement" section. If error persists proceed to the next step.</li> <li>2. Replace non-functioning element. See "Heating Element Replacement" section.</li> </ol>
<b>ELC</b>	Lower element is not functioning	<ol style="list-style-type: none"> <li>1. Turn off power at the circuit breaker/fuse box and check for a loose connection at the element. For access directions see "Heating Element Replacement" section. If error persists proceed to the next step.</li> <li>2. Replace non-functioning element. See "Heating Element Replacement" section.</li> </ol>
<b>SF</b>	The air filter is dirty.	<ol style="list-style-type: none"> <li>1. Turn off power at the circuit breaker/fuse box.</li> <li>2. Clean the air filter. See "Air Filter Cleaning/Replacement" section.</li> </ol>
<b>ECF</b>	The heat pump compressor is starting/stopping frequently.	<ol style="list-style-type: none"> <li>1. Turn off power at the circuit breaker/fuse box.</li> <li>2. Clean the air filter. See "Air Filter Cleaning/Replacement" section.</li> <li>3. If error persist, please contact a qualified person to check the fan wire connection.</li> </ol>
<b>E20 or E21</b>	Upper Temperature Sensor is not functioning.	Contact a qualified person to service the unit.
<b>E30 or E31</b>	Lower Temperature Sensor is not functioning.	
<b>E50 or E51</b>	Heat Pump Suction Temperature Sensor is not functioning.	
<b>E10 or E11</b>	Heat Pump Coil Temperature Sensor is not functioning.	
<b>E40 or E41</b>	Heat Pump Discharge Temperature Sensor is not functioning.	
<b>Edr</b>	Not enough water in the tank (tank not full).	Fill completely-Open all hot water taps in home and run until water (uninterrupted) flows from all open hot water taps.
<b>EPL</b>	Power supply voltage is too low.	Check the power supply to the unit and make sure it is higher than 204V
<b>EDH</b>	Heat Pump Discharge Temperature is too high.	Contact a qualified technician to service the unit.
<b>EoF (If Accessory Condensate Pump is installed)</b>	Condensate pump failure.	<ol style="list-style-type: none"> <li>1. Check to see if accessory condensate pump is plugged in and has power. Also check circuit breaker/fuse box and GFCI (if used). If error persists, proceed to the next step.</li> <li>2. Check condensate pump outlet tube for blockage. If error persists, proceed to the next step.</li> <li>3. Check control wire connections to condensate pump. If error persists, proceed to the next step.</li> <li>4. Replace accessory condensate pump. If error persists, contact a qualified technician to service the unit.</li> </ol>
<b>ECL</b>	Heat pump suction pressure is too low.	Contact a qualified technician to service the unit
<b>EEE</b>	EEPROM failure	
<b>ECC</b>	Heat pump compressor is not functioning.	
<b>"_","_","_","_"</b>	Unit is doing a system diagnostic.	No action is necessary.
<b>ICE</b>	Heat pump is in defrosting cycle.	
<b>HPO</b>	Heat pump is out of operation envelope.	

**NOTE:** The diagnostic codes listed above are the most common. If a diagnostic code not listed above is displayed, contact Residential Technical Assistance referencing the number on the front of this manual.

# TROUBLESHOOTING CHART

PROBLEM	POSSIBLE CAUSE(S)	CORRECTIVE ACTION
<b>NO HOT WATER</b>	<ol style="list-style-type: none"> <li>No power to the water heater (No lights on the unit are on).</li> <li>Unit in Vacation mode</li> <li>High temperature limit switch open</li> <li>Hot water usage pattern exceeds the capability of the water heater in current mode</li> <li>Non-functioning upper temperature sensor</li> </ol>	<ol style="list-style-type: none"> <li>Check for blown fuse or tripped breaker. Restore power to unit.</li> <li>Press Mode/Enter button and return to desired operating mode.</li> <li>Reset the high temperature limit switch; see "Safety shut-off" section for more information.</li> <li>Change to different mode or modify usage patterns.</li> <li>Contact a qualified person for service.</li> </ol>
<b>INSUFFICIENT HOT WATER/ SLOW HOT WATER RECOVERY</b>	<ol style="list-style-type: none"> <li>Temperature set-point too low</li> <li>Air filter dirty</li> <li>Hot water usage pattern exceeds the capability of the water heater in current mode</li> <li>Water connections to unit reversed</li> <li>Heat lost through long run of exposed pipe</li> <li>Hot water leak at faucet or piping</li> <li>Non-functioning heating element</li> <li>Sediment or scale build up in tank</li> </ol>	<ol style="list-style-type: none"> <li>Increase set point temperature; see "Adjusting the User Interface Module" section</li> <li>Clean air filter</li> <li>Change to different mode or modify usage patterns (For example if in Efficiency Mode switch to Hybrid Mode)</li> <li>Ensure the cold connection is at the bottom and that the hot connection is at the top</li> <li>Insulate exposed piping</li> <li>Repair hot water leaks</li> <li>Call qualified person for service</li> <li>Drain and flush tank. Water conditioning may be necessary to minimize build up</li> </ol>
<b>HIGH OPERATION COSTS</b>	<ol style="list-style-type: none"> <li>Temperature set-point too high</li> <li>Air filter dirty</li> <li>Electric mode selected</li> <li>Water connections to unit reversed</li> <li>Heat lost thru long run of exposed pipe</li> <li>Hot water leak at faucet or piping</li> <li>Sediment or scale build up in tank</li> </ol>	<ol style="list-style-type: none"> <li>Decrease set point temperature; see "Adjusting the User Interface Module"</li> <li>Clean air filter</li> <li>Change to Efficiency or Hybrid mode for reduced energy costs</li> <li>Ensure the cold connection is at the bottom and that the hot connection is at the top</li> <li>Insulate exposed piping</li> <li>Repair hot water leaks</li> <li>Drain and flush tank. Water conditioning may be required to minimize build up</li> </ol>
<b>DRIP FROM TEMPERATURE &amp; PRESSURE RELIEF VALVE (Warning: Do not plug or cap T&amp;P discharge pipe.)</b>	<ol style="list-style-type: none"> <li>Excessive water pressure</li> <li>Add or service a thermal expansion tank.</li> <li>Non-functioning Temperature &amp; Pressure Relief Valve</li> </ol>	<ol style="list-style-type: none"> <li>Check water supply inlet pressure. If higher than 80 PSIG, install a pressure reducing valve (50-60 PSIG is the recommended pressure.)</li> <li>See "Closed System/Thermal Expansion" section</li> <li>Replace the Temperature &amp; Pressure Relief Valve</li> </ol>
<b>OTHER</b>	<ol style="list-style-type: none"> <li>The water heater does not immediately start</li> <li>The heat pump does not run in Efficiency mode.</li> </ol>	<ol style="list-style-type: none"> <li>When first started the water heater takes about 8 minutes to complete a diagnostic routine</li> <li>Contact a qualified person for service</li> </ol>

# REPAIR PART ILLUSTRATION

Figure 17

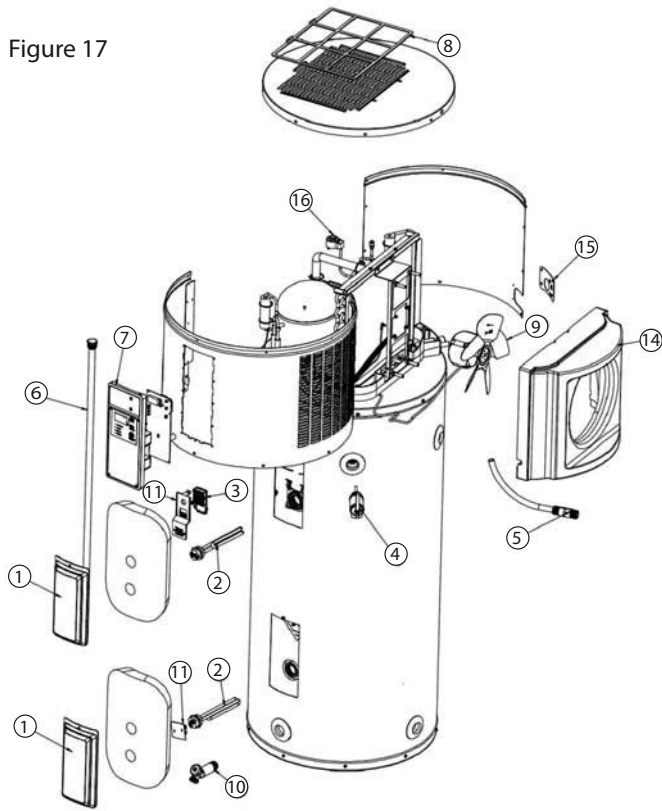

## REPAIR PARTS LIST

ITEM NO.	PARTS DESCRIPTION
1	Element Access Cover
2	Element (4500 Watts)
3	Energy Cut-Off (ECO) Switch
4	Temperature & Pressure Relief Valve (T&P)
5	Dip Tube (at hot water outlet)
6	Anode
7	Controller
8	Air Filter
9	Fan Assembly
10	Drain Valve
11	Element Terminal Cover
12	Ambient / Coil / Discharge Temperature Sensor*
13	Upper / Lower Tank Temperature Sensor*
14	Fan Shroud
15	Condensate Drain Connection Cover
16	Electronic Expansion Valve Coil
17	Start Capacitor*
18	Relay Kit*

\* NOT SHOWN

## REPAIR PARTS

Repair parts may be ordered through your plumber, local distributor, home improvement center, or by calling 1-800-527-1953. When ordering repair parts always give the following information:

1. Model, serial and product number
2. Item number
3. Parts description



®/™ ©2014 Whirlpool. All rights reserved.  
Manufactured under license by A.O. Smith, Tennessee.  
Warranty provided by manufacturer.